

# F-17 Series (∅ 17.0mm)

## Metal Shaft Rotary Potentiometer

### F-17N

Standard Type, Single Unit

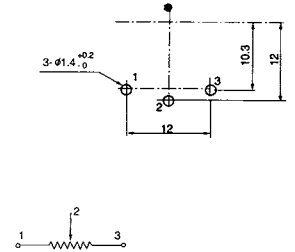
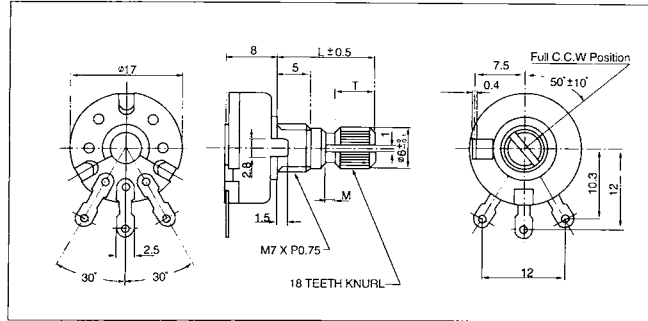
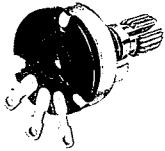

### F-17S

Standard Type with Switch,  
Single Unit

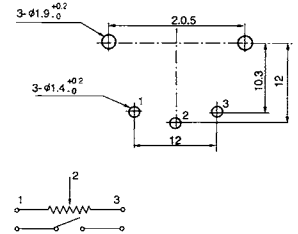
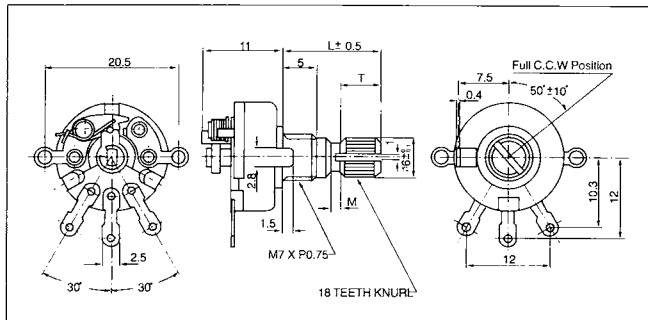
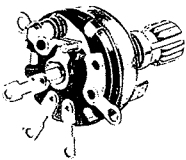

### F-17NP1

Horizontal Type, Single Unit

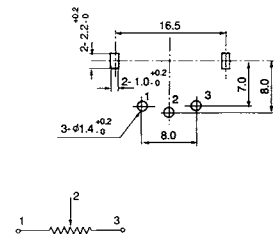
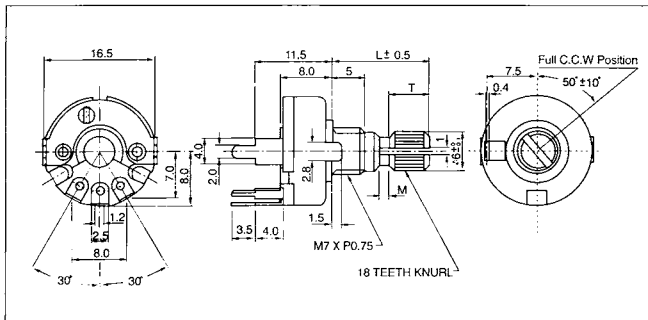
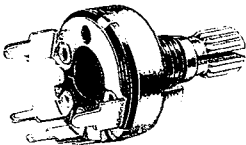

### F-17NPD

Reverse Type, single Unit

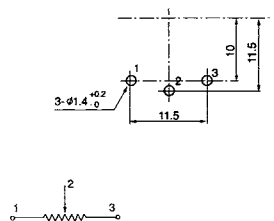
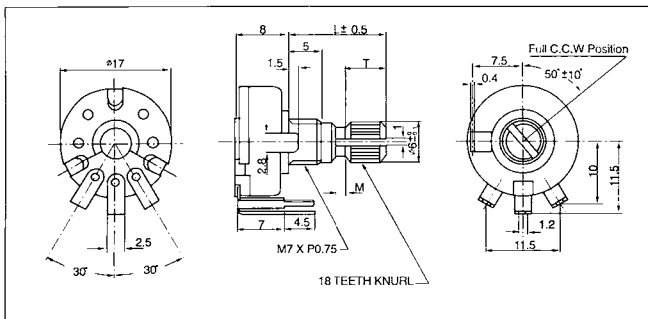
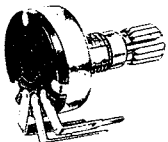

### F-17SP

Horizontal Type with Switch,  
single Unit

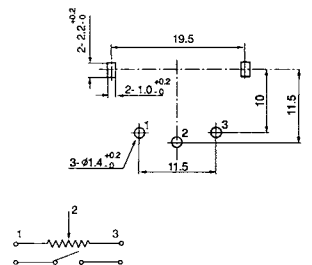
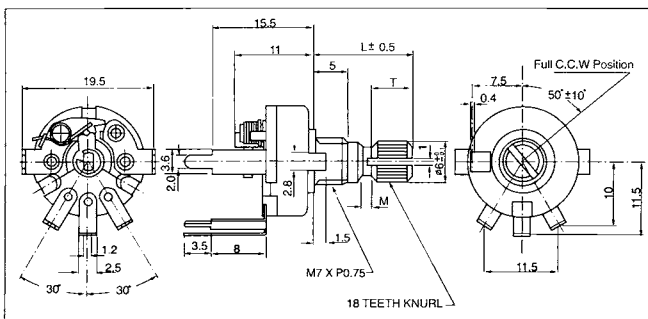
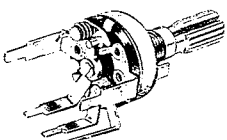

# F-17 Series (∅ 17.0mm)

## Metal Shaft Rotary Potentiometer

### F-17SPD

Reverse Type with Switch,  
Single Unit, P.C.B Terminal

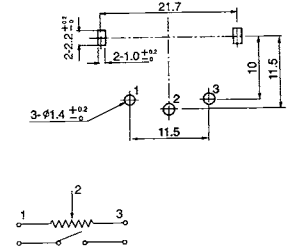
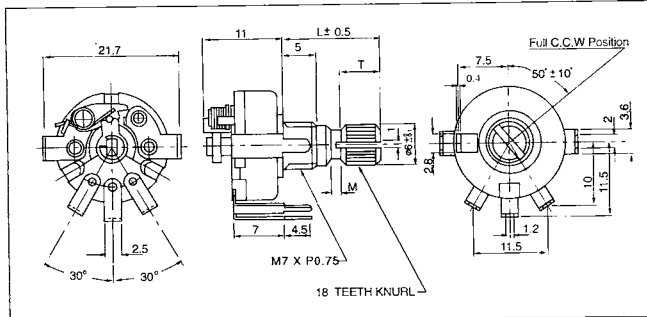
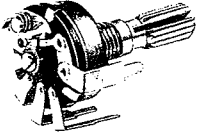

### F-17S2

Mixture Type with Switch,  
Single Unit, P.C.B Terminal

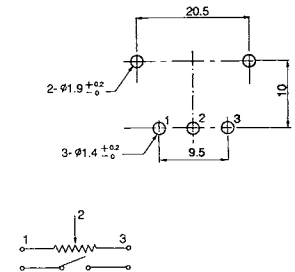
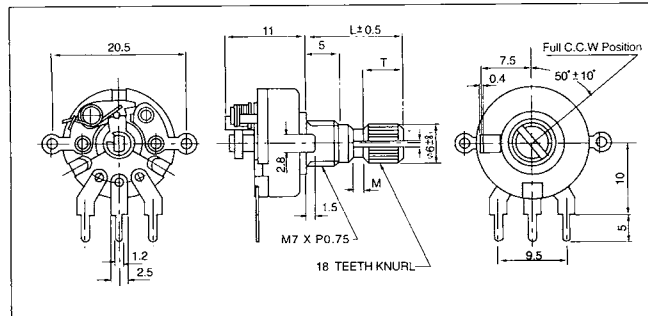
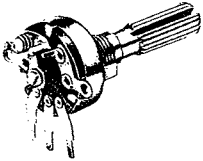

### F-17N2

Vertical Type, Single Unit  
P.C.B Terminal

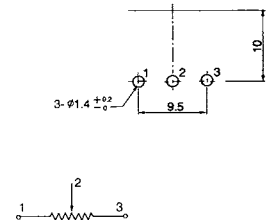
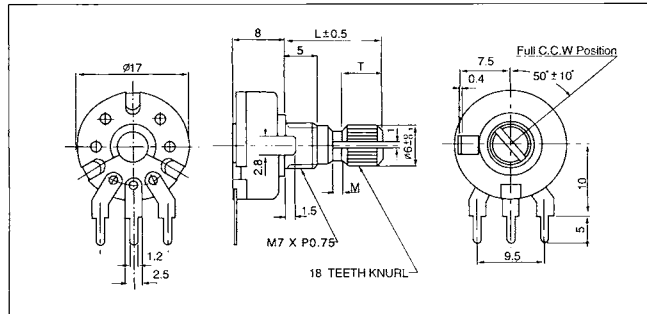
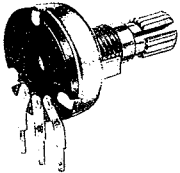

### F-17SP1

Horizontal Type, Single Unit  
P.C.B Terminal

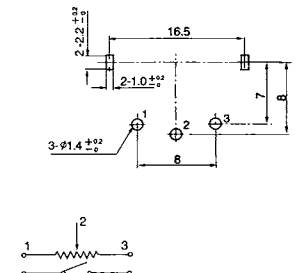
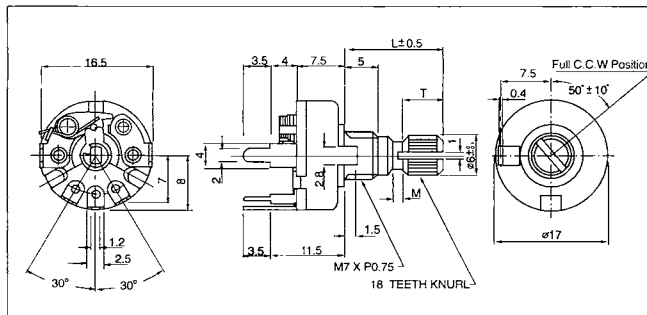
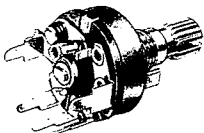

# F-17 Series (∅ 17.0mm)

## Metal Shaft Rotary Potentiometer

### F-17S-10

Vertical Type with Switch, Single Unit Solder Terminal.

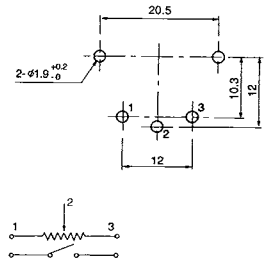
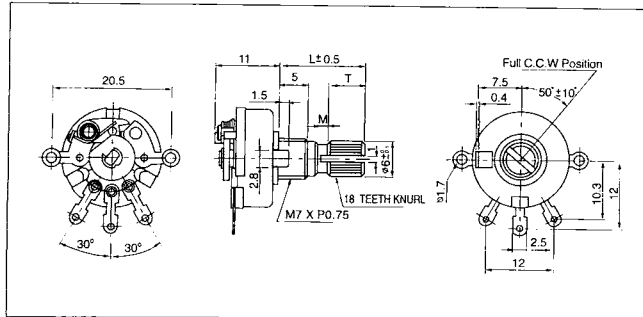
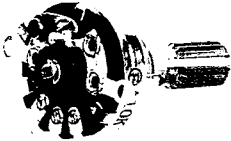

### F-17NP3

Horizontal Type, Single Unit. P.C.B. Terminal.

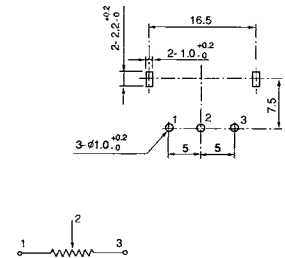
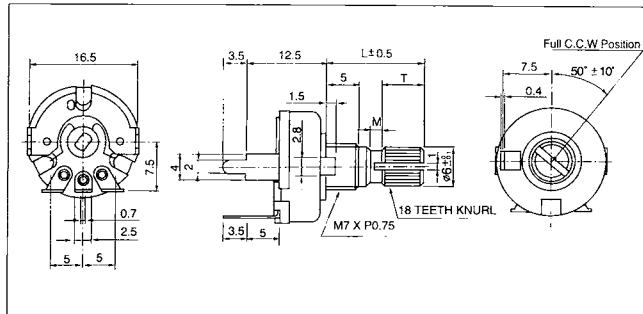

### F-17SW

Switch only,

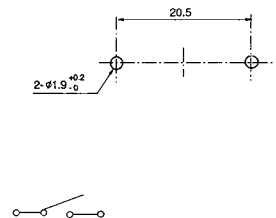
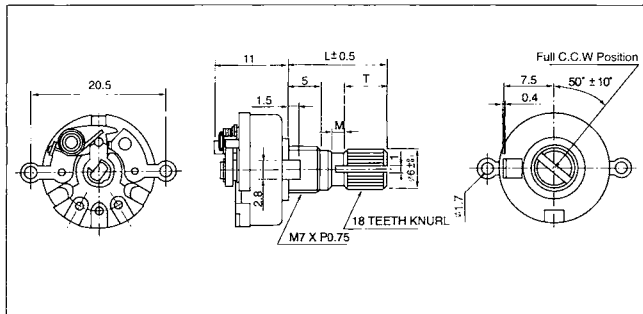

### F-17SP8

Horizontal Type with Switch, Single Unit, P.C.B. Terminal

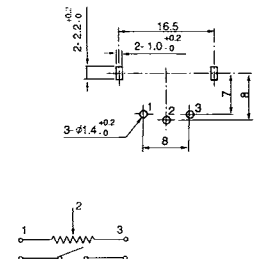
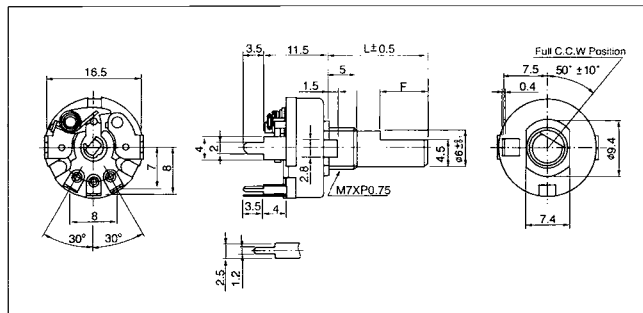

### F-17SNP3

Horizontal Type, Single Unit, P.C.B. Terminal

