

1	MODEL	F30M44B (30CS08MSX-50BD1)			
2	Dimension	Outer Diameter	30 mm	Baffle Opening	27.2 mm.
		Height Refer to drawing	Weight	5.0	Gram.
3	Magnet	Materials	Rare Earth	Size	ø9.5X1.5 mm.
4	Nominal Impedance	8 Ohm	± 15 %	At	1000 Hz
5	Power Rating	Normal	2.0 W.	Maximum	3.0 W.
6	Lowest Resonant Frequency	570	±	114	Hz
7	Output Sound Pressure Level (S.P.L.)	79 ± 3 db / 1 Watt 1 Meter.			
		Average at	800,1000,1200,1500	HZ	
8	Frequency Range	300~6000	Hz.	Average SPL-10 db.	
9	Distortion	5 %	Maximum At	1000 Hz	2.0 W.
10	Abnormal Sound Test	Must be Normally Tested By		4.0	Volts Sine Wave.
11	Load Test	White Noise with Weighted Filter		4.0	Volts. (RMS) 24 Hrs.
12	Operation Temperature	-25°C ~ +60°C 16 Hours.			
13	Storage Temperature	-40°C ~ +70°C 2 Hours.			
14	Polarity	Diaphragm shall move Forward when Apply a Positive DC			
		Current to the "+" or "Marked" Terminal.			
15	Remarks	Above specifications on the strength of CNS4784 and CNS4785.			

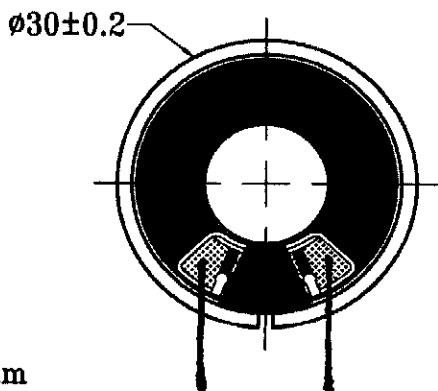

1.3±0.2

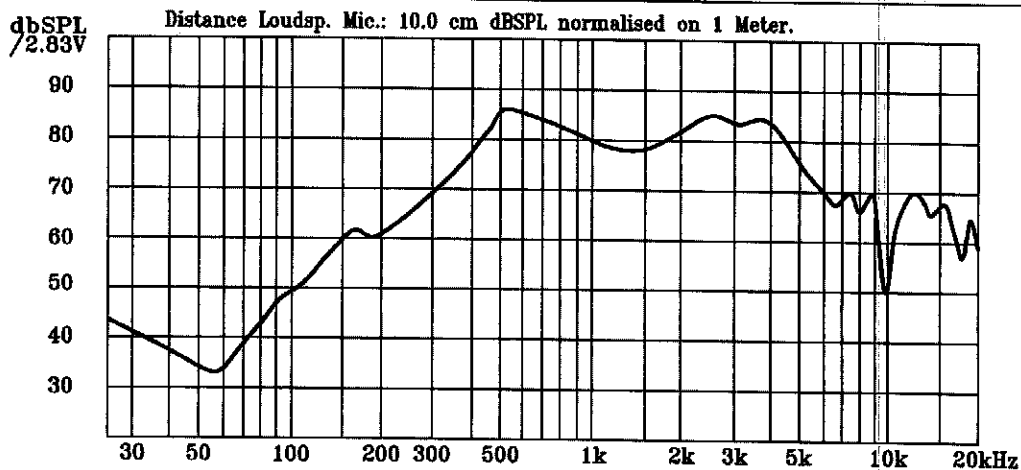
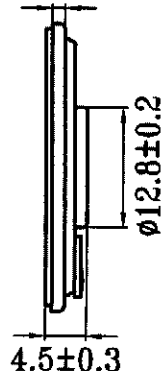

At Least
0.5mm
For
Diaphragm
Moving



Unit:mm

0303C